

MID:COM E:Count LTIS

E:Count LTIS MCR-09 Installation Guide

Reference for Installing the
MID:COM E:Count LTIS MCR-09 Electronic Register



Midwest Computer Register, Corp.
1605 170th Street
Hampton, IA 50441

Telephone: 641-456-4848
Fax: 641-456-4600
E-Mail: Sales@MidComCorp.com
Web: www.MidComCorp.com

MID:COM THE ONE THAT WORKS!

TABLE OF CONTENTS

TABLE OF CONTENTS	2
TABLE OF FIGURES	4
SECTION 1 - SPECIFICATIONS	7
REGISTER PHYSICAL	7
PCM PHYSICAL	7
ENVIRONMENTAL	8
ELECTRICAL	8
REGULATORY	8
SECTION 2 – OVERVIEW	9
MID:COM LTIS REGISTER INSTALLATION	9
SECTION 3 – CONTROL DRAWING	10
CONTROL DRAWING	10
Figure 1. MCR-09 LTIS CONTROL DRAWING	11
SECTION 4 – POWER CONTROL MODULE	12
SECTION 5 – WIRING OVERVIEW	13
WIRING OVERVIEW	13
SPECIFIC WIRING	13
SECTION 6 – POWER SUPPLY MAINS WIRING	14
POWER SUPPLY MAINS WIRING	14
240 VAC MAINS WIRING	14
Figure 3. 240 VAC MAINS WIRING DETAILS	14
120 VAC MAINS WIRING	15
Figure 4. 120 VAC MAINS WIRING DETAILS	15
SECTION 7 – RELAY WIRING	16
RELAY OUTPUT FUNCTIONS	16
RELAY 1 (PRESET STAGE 1)	16
Relay 2 (PRESET STAGE 2)	16
RELAY 3 (INTERNAL VALVE)	16
RELAY 4 (PUMP CONTROL)	16
RELAY WIRING	17
Figure 5. RELAY CONNECTOR WIRING DETAILS	17
SECTION 8 – REGISTER WIRING	18
REGISTER WIRING	18
Figure 6. REGISTER CONNECTOR WIRING DETAILS	18
SECTION 9 – CONTROL BOARD CONNECTIONS	19
CONTROL BOARD CONNECTIONS	19
Figure 7. CONTROL BOARD CONNECTION DETAILS	19
SECTION 10 – FUEL MANAGEMENT SYSTEM	20
FUEL MANAGEMENT SYSTEM (FMS) WIRING	20
PULSE OUTPUT FROM LTIS	20
Figure 8. PULSE OUTPUT TIMING DIAGRAM	20

FMS AUTHORIZATION	22
AUTHORIZATION WIRING	23
Figure 9. FUEL MANAGEMENT SYSTEM CONNECTOR (J1)	24
Figure 10. OUTPUT 2 PULLUP JUMPER (J12) SET FOR +12 VDC	24
SECTION 11 – REMOTE PULSER WIRING	25
REMOTE PULSER WIRING – MID:COM MODEL PT-10	25
Figure 11. REMOTE PULSER CABLE CONNECTOR (J4)	25
Figure 12. PT-10 REMOTE PULSER LTIS CABLE CONNECTION	25
Figure 13. PT-10 REMOTE PULSER CONNECTOR AND JUMPERS	26
MID:COM MODEL PT-10 – ELECTRICAL WIRING	27
SECTION 12 – PRINTER WIRING	28
PRINTER WIRING	28
Figure 14. PRINTER WIRING DETAILS (J3)	29
SECTION 13 - TROUBLESHOOTING	31
TROUBLESHOOTING OVERVIEW	31
TROUBLESHOOTING PT-10 REMOTE PULSE TRANSMITTER	31
VOLTAGE CHECKS	32
TROUBLESHOOTING PULSE OUTPUT TO FMS	33
TROUBLESHOOTING AUTHORIZATION INPUT FROM FMS	33
INDEX	34
VERSION HISTORY	35

TABLE OF FIGURES

Figure 1. MCR-09 LTIS CONTROL DRAWING	11
Figure 2. POWER CONTROL MODULE OVERVIEW	12
Figure 3. 240 VAC MAINS WIRING DETAILS	14
Figure 4. 120 VAC MAINS WIRING DETAILS	15
Figure 5. RELAY CONNECTOR WIRING DETAILS	17
Figure 6. REGISTER CONNECTOR WIRING DETAILS	18
Figure 7. CONTROL BOARD CONNECTION DETAILS	19
Figure 8. PULSE OUTPUT TIMING DIAGRAM	20
Figure 9. FUEL MANAGEMENT SYSTEM CONNECTOR (J1)	24
Figure 10. OUTPUT 2 PULLUP JUMPER (J12) SET FOR +12 VDC	24
Figure 11. REMOTE PULSER CABLE CONNECTOR (J4)	25
Figure 12. PT-10 REMOTE PULSER LTIS CABLE CONNECTION	25
Figure 13. PT-10 REMOTE PULSER CONNECTOR AND JUMPERS	26
Figure 14. PRINTER WIRING DETAILS (J3)	29

Trademarks

MID:COM *E:Count* and *their integrated software and hardware components* are trademarks of Midwest Computer Register Corp. (MID:COM). *Microsoft, MS, and MS-DOS* are registered trademarks, *Windows* is a trademark of Microsoft Corporation. Other brand and product names mentioned in this publication are trademarks or registered trademarks of their respective holders.

Copyright Notice

ECount LTIS Installation Guide v1.05.docx

© 2012-2013 Midwest Computer Register, Corp. All rights reserved. Neither this publication nor any part of this publication may be copied, photocopied, reproduced, translated, or reduced to any electronic medium or machine readable form without the prior written permission of:

Midwest Computer Register, Corp.
1605 170th St.
PO Box 376
Hampton, Iowa 50441, USA
641-456-4848
www.midcomcorp.com
sales@midcomcorp.com

Disclaimer

Midwest Computer Register, Corp. provides this document and the software "as is" without any warranty of any kind, either expressed or implied; including but not limited to, the implied warranties of merchantability or fitness for a particular purpose.

Midwest Computer Register, Corp. reserves the right to make improvements and modifications to this document, and the products described in this document, at any time and without notice.

Midwest Computer Register, Corp. shall not be liable for any errors contained herein or for incidental and consequential damages in connection with the furnishings, performance, or use of this material.

Contact Information

You have several ways to interact with Midwest Computer Register, Corp. and its staff. If you have a suggestion you can email, write, or call us.

Email

Sales: sales@midcomcorp.com
Support: <http://www.midcomcorp.com/Contact.html>

Postal Address

MID:COM
1605 170th St
PO Box 376
Hampton, Iowa 50441

Phone Numbers

Phone: 641-456-5205
Fax: 641-456-4600

SECTION 1 - SPECIFICATIONS

The **MID:COM E:Count LTIS MCR-09 Register and Intrinsically Safe Power Control Module (PCM)** are designed for metering applications in the presence of Hazardous Atmospheres such as Propane and Gasoline. The device consists of two modules; the Register Module which serves as the user interface and the Power Control Module which supplies Intrinsically Safe power to the Register and controls external relays and communication devices. This guide will describe and illustrate the proper methods of installation and wiring so as to maintain the Explosion-Proof and Intrinsically Safe methods of protection for Hazardous (Classified) Locations.

For operating, programming and additional information refer to the MCR-09 Operation Manual.

REGISTER PHYSICAL

Height: 5.75"
Width: 8.75"
Depth: 2.85" (3.85" including conduit hubs)
Weight: 3 lbs
Material: Powder coated cast aluminum. Stainless Steel hardware.
Mounting: (4) 1/4-20 holes on 1.5" square bolt pattern.
Pulser Drive: 0.5" hollow slotted shaft. 0.25" pin drive for meter connection.
Keyboard: Polyester and Acrylic metal dome membrane. Polycarbonate lens.
Conduit Hub: Listed, water tight 1/2".

PCM PHYSICAL

Height: 4.5"
Length: 10.5"
Width: 4.5"
Weight: 8.5 lbs
Conduit Hubs: (1) – 3/4" for user installation
(1) – 1/2" for user installation
(2) – 1/2" for Intrinsically Safe Circuits to Register and Temperature Probe.
These hubs are dedicated to these functions and are supplied with factory sealed nipples and are not to be used for any other purpose. Refer to Power Control Module (PCM) Overview.

All hubs are machined to +1/2 to +3 threads of a standard plug gage, insuring a minimum of 5 full threads of a mating conduit fitting.

ENVIRONMENTAL

Outdoor use	
Altitude:	Up to 2000 M
Temperature:	-40 to +55C
Relative Humidity:	0 – 100%
Register Enclosure:	NEMA 4
PCM Enclosure:	NEMA 7 (Explosion Proof)

ELECTRICAL

Input Power:	120/240 VAC, 1A 50/60 Hz.
Fuses:	Listed 250VAC/DC .1A 5x20 mm cartridge.
Pulse Input	0 - 5 VDC, 1 ms min High time.
Pulse Output:	Open collector. Optional pull-up resistors. 1K ohm to +12VDC or 470 ohm to +5VDC
Pulse Width:	5 ms high, min 5 ms low between pulses. One pulse per increment of least significant digit.
Analog Input:	Temperature probe; 100 Ohm Platinum RTD
Communication:	RS-232 (2) Printer port, Host/Program Port
Relay Outputs:	(4) <ol style="list-style-type: none">1. Delivery authorized2. Delivery begin. (pump start)3. Preset volume 1st stage.4. Preset volume 2nd stage.
Relay contact ratings:	+30 VDC/250 VAC 3A max.

REGULATORY

Ratings:	
Temperature:	Code T4 (135 C)
Classification	
and Approvals:	Class I Division 1, or Division 2, Groups C and D ETL Listed, Control # 4006333 U.S. NTEP COC 06-031 (Weights and Measures)

SECTION 2 – OVERVIEW

MID:COM LTIS REGISTER INSTALLATION

This Device is Listed and Approved for installation in Class 1 Division 1 and 2 Group C and D Hazardous Locations. All wiring must be in accordance with the National Electrical Code Publication NFPA 70 Article 500 and performed by a licensed Electrician familiar with the Hazardous Location installations.

WARNING – EXPLOSION HAZARD – DO NOT DISCONNECT EQUIPMENT WHILE THE CIRCUIT IS LIVE OR UNLESS THE AREA IS KNOWN TO BE FREE OF IGNITABLE CONCENTRATIONS OF FLAMMABLE GAS.

WARNING – EXPLOSION HAZARD – SUBSTITUTION OF ANY COMPONENT MAY IMPAIR SUITABILITY FOR CLASS 1 DIVISION 1 OR 2 LOCATIONS.

SECTION 3 – CONTROL DRAWING

CONTROL DRAWING

The following discussion refers to the Control Drawing and pictorial on the following pages. The Control Drawing depicts the important aspects of the proper wiring to insure compliance with the protection methods employed for Hazardous Locations and Intrinsically Safe (IS) circuits.

The left conduit hub is for high voltage mains and relay wiring. The front hub is for low voltage peripherals and communication wiring. These circuits should not be mixed to reduce the possibility of interference and cross-talk. Neither of the circuits are Intrinsically Safe and must be supplied with Listed seal-offs within 18 inches of the enclosure. We recommend installing the seal-offs adjacent to the enclosure and then providing a conduit union on the other side of the seal-off so that the device can more easily be replaced if necessary. All wire slack must be removed and wires routed and tied so there is no possibility of any wires coming in contact with the Temperature PCB (refer to Note 1 on the Control Drawing).

The conduit hubs on the right are Intrinsically Safe Circuits. One is for the register connections and the other is for the Temperature Compensator RTD Probe. Both are factory sealed and are not to be substituted with any other type of fitting. If the probe needs replacement the entire assembly including the sealed fitting is replaced. The register wires are supplied as a 12 conductor cable with a light blue jacket indicating Intrinsically Safe circuits. Since conduit is not required for IS circuits a cable compression fitting is supplied for both the Power Control Module (PCM) and the Register. If conduit is desired then the compression fittings can be substituted with other types of fittings without affecting the IS status.

Figure 1. MCR-09 LTIS CONTROL DRAWING

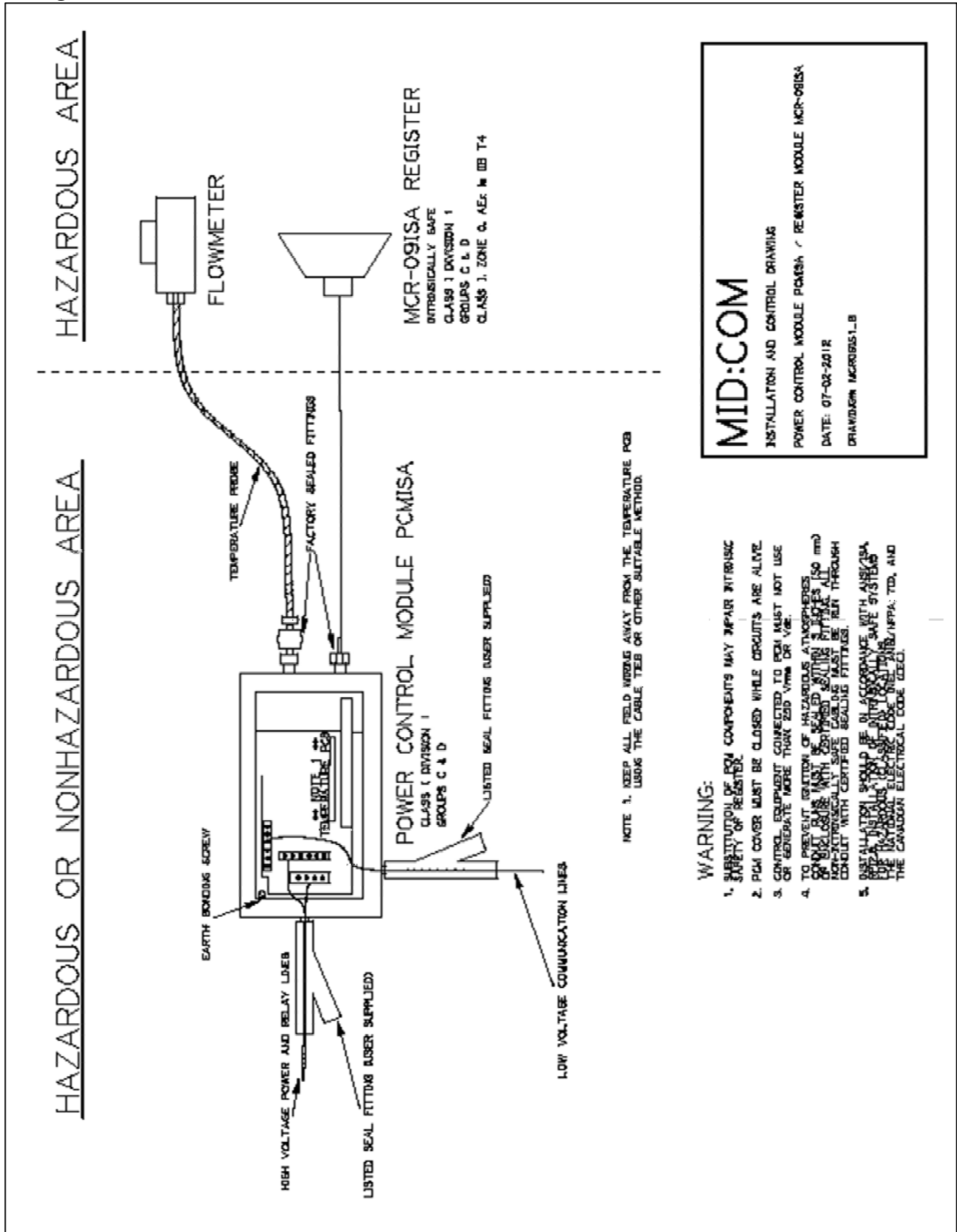

SECTION 4 – POWER CONTROL MODULE

Figure 2. POWER CONTROL MODULE OVERVIEW

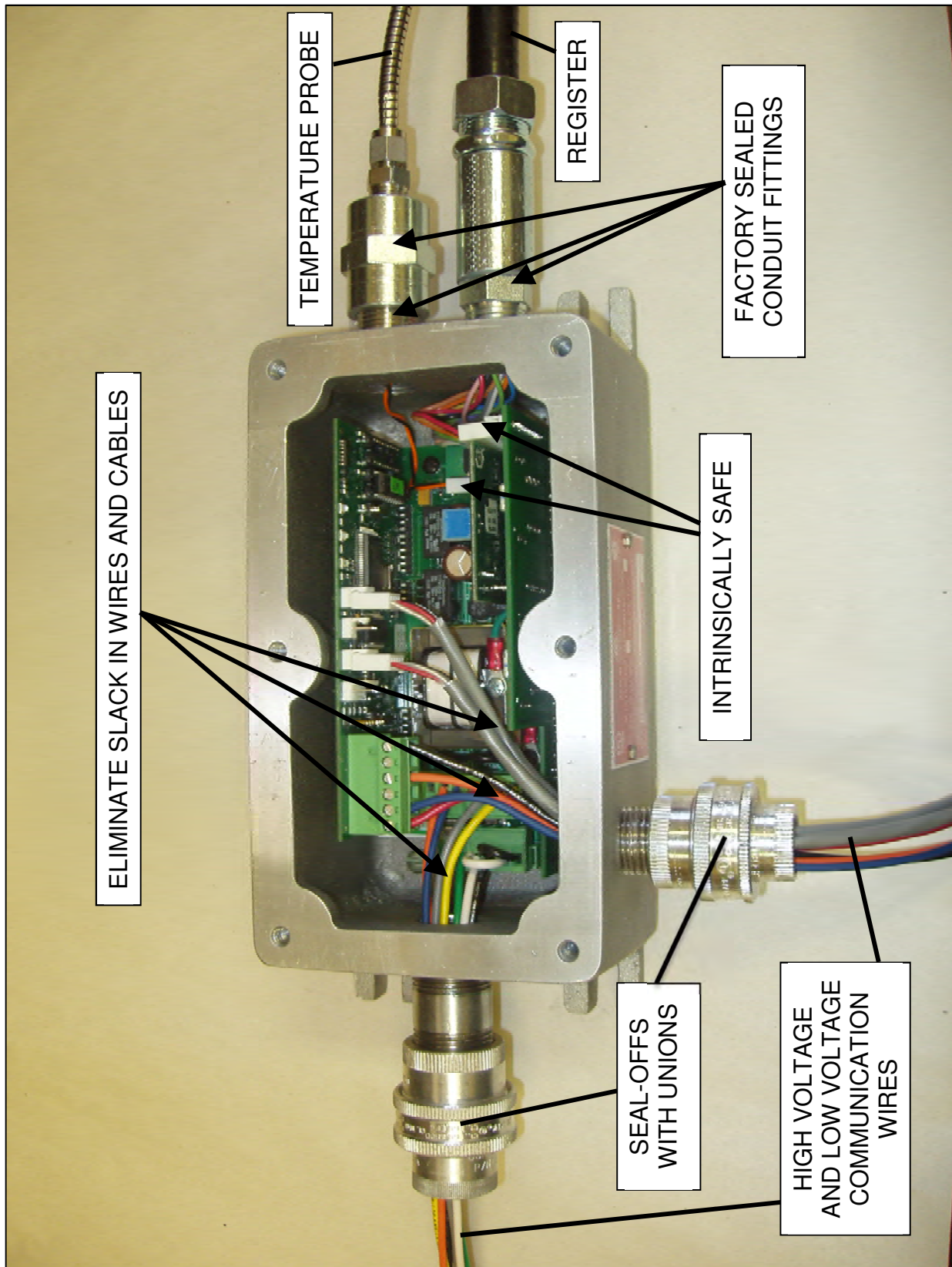

SECTION 5 – WIRING OVERVIEW

WIRING OVERVIEW

Field wiring for power, relays and interface to other vendors devices is done with installer supplied 18-16 gauge stranded wire. Due to the cramped conditions in the enclosure 18 gauge is recommended. These wires terminate to screw clamp pluggable terminal blocks. Remote Pulsers, Printers, etc. require factory supplied cables and terminate to post headers on the PCB. All wire slack must be removed from the enclosure before closing it up.

SPECIFIC WIRING

The following pages explain the specific areas of wiring for the LTIS. Photos show actual wiring and where applicable a portion of the schematic is shown so the installer has a better idea of where the connections are going internal to the device. Since this document is aimed at installing the LTIS in conjunction with an LP gas dispenser the schematics can be very helpful when interfacing to other devices like Fuel Management Systems (FMS).

Each of the following are explained in more detail in the next sections:

1. Mains Wiring
2. Relay Wiring
3. Register Wiring
4. Control Board Connections
5. Fuel Management System
 - a. Pulse output from LTIS to FMS
 - b. Authorization output from FMS to LTIS
6. Remote Pulser Wiring
7. Printer Wiring
8. Wiring Troubleshooting

**** WARNING ****

**PROPER INSTALLATION REQUIRES
TWO DEDICATED CIRCUITS**

- PUMP MOTOR POWER
- LTIS WITH ASSOCIATED VALVES,
MOTOR CONTACTORS, ETC.

SECTION 6 – POWER SUPPLY MAINS WIRING

POWER SUPPLY MAINS WIRING

The LTIS can operate on either 120 VAC or 240 VAC. The dual-winding transformer can be wired for either voltage as shown below. Pin 5 (Earth Ground) is internally connected to the board mounting screws and enclosure so that a connection to the enclosure bonding screw is not necessary.

240 VAC MAINS WIRING

Figure 3. 240 VAC MAINS WIRING DETAILS

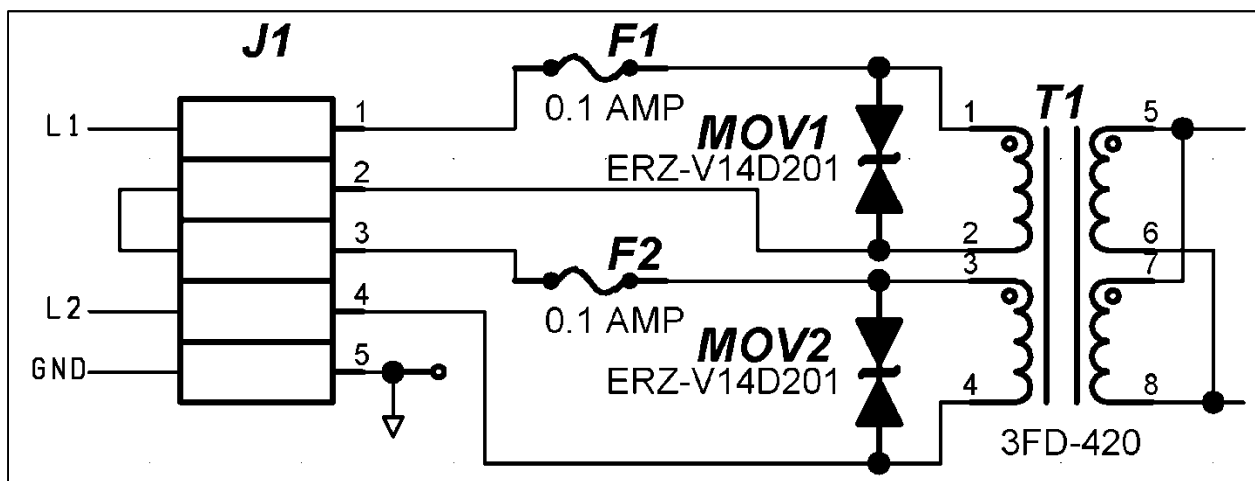
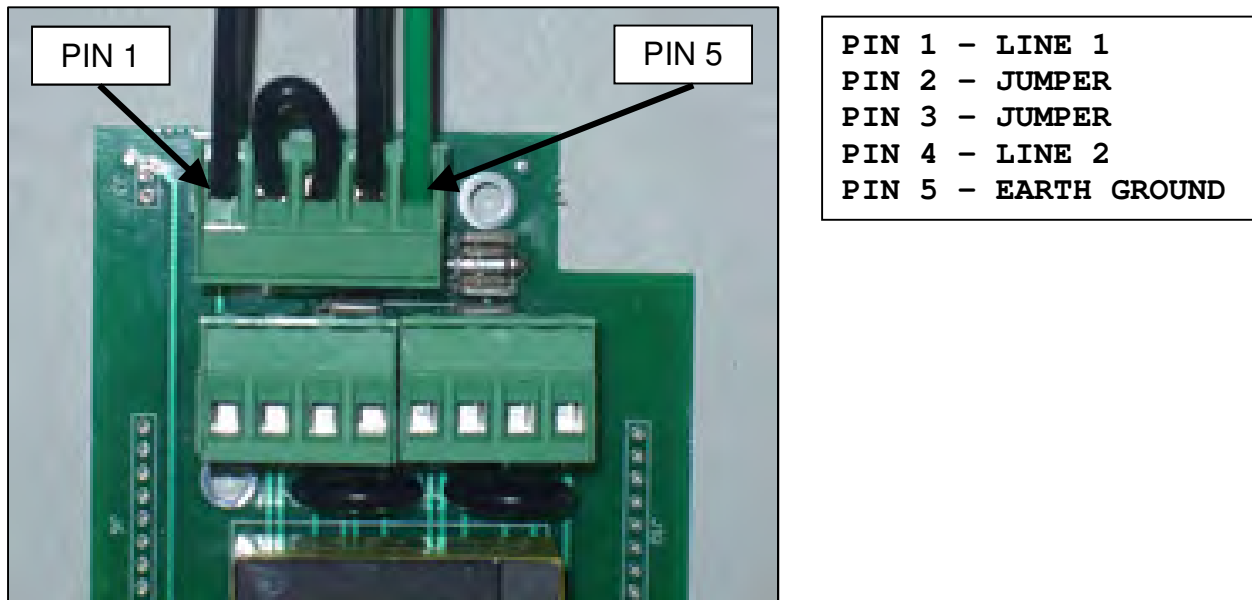

120 VAC MAINS WIRING

Figure 4. 120 VAC MAINS WIRING DETAILS

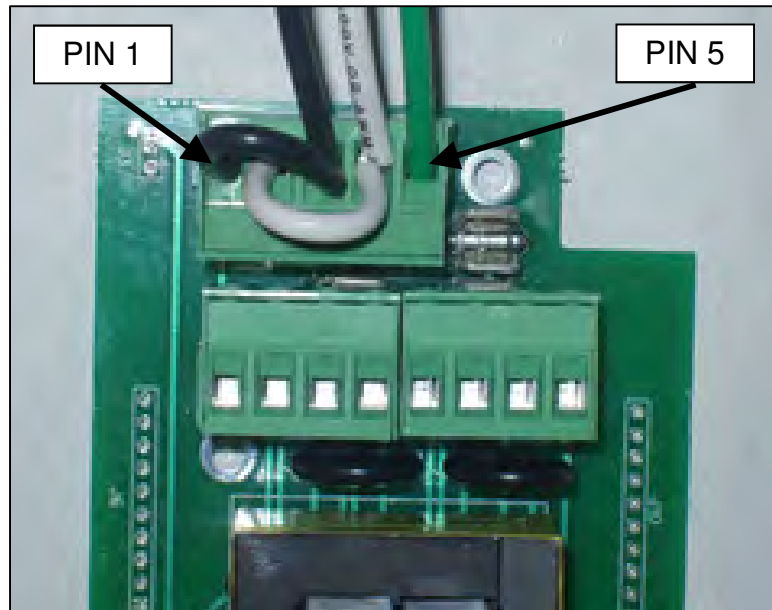

- PIN 1 - LINE JUMPER
- PIN 2 - NEUTRAL JUMPER
- PIN 3 - LINE + JUMPER
- PIN 4 - NEUTRAL + JUMPER
- PIN 5 - EARTH GROUND

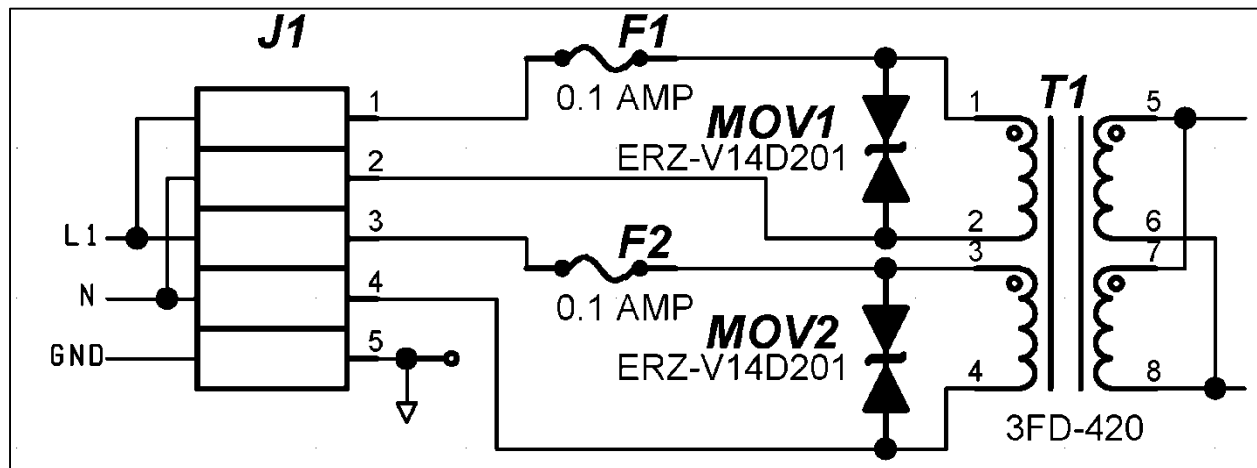

SECTION 7 – RELAY WIRING

RELAY OUTPUT FUNCTIONS

Four relays with Normally Open (NO) and COM terminals provide for different functions before, during, and after a new delivery starts. The start of a new delivery is when register is authorized and the START/STOP key on the register is pressed. The end of the delivery occurs when the START/STOP key is pressed again, the no-flow timer (if enabled) has timed out, or the FMS has de-authorized the register. The descriptions below are for typical applications as other options are possible. All relays are open before the start of a new delivery. Please see SPECIFICATIONS for relay ratings.

RELAY 1 (PRESET STAGE 1)

Relay 1 is used with a 2-stage flow control valve in line with the output of the flowmeter for preset volume deliveries. The relay will close at the start of a new delivery and will open when the delivered volume reaches the Stage 2 volume setting. This allows for a slowdown in product flow prior to final shutoff.

Relay 2 (PRESET STAGE 2)

Relay 2 closes after Relay 1 opens. This turns on the second stage preset valve for a slow-flow condition. The relay will open when the delivered volume reaches the Stage 2 setting.

RELAY 3 (INTERNAL VALVE)

Relay 3 closes as soon as the START/STOP key is pressed and the register reset cycle starts. The reset cycle takes several seconds, so this relay is usually used to open the supply tank internal valve on a dispenser before the pump is activated. The relay opens when the delivery has ended.

RELAY 4 (PUMP CONTROL)

Relay 4 closes after the register is done with the reset cycle and the register is at a "zero reset". This relay is usually used in a dispenser application to start the pump motor and begin product flow. The relay opens when the delivery has ended.

The following page depicts the relay terminal block and wiring.

RELAY WIRING

- *Figure A* below shows the internal wiring of the 4 relays.
- *Figure B* below shows a typical application using 120 VAC solenoids for tank internal valve control.
- *Figure C* below shows an application where a 12 VDC solenoid is used for internal valve control. Note that although the LTIS has 12 VDC available to external devices it is only meant for very light loads like pull-up resistors. For valve control an external DC source is required. Also note the diode across the solenoid coil. The diode needs to be installed to suppress the inductive spike that occurs when the solenoid turns off. A 2A-200V (or greater) diode is required.

Figure 5. RELAY CONNECTOR WIRING DETAILS

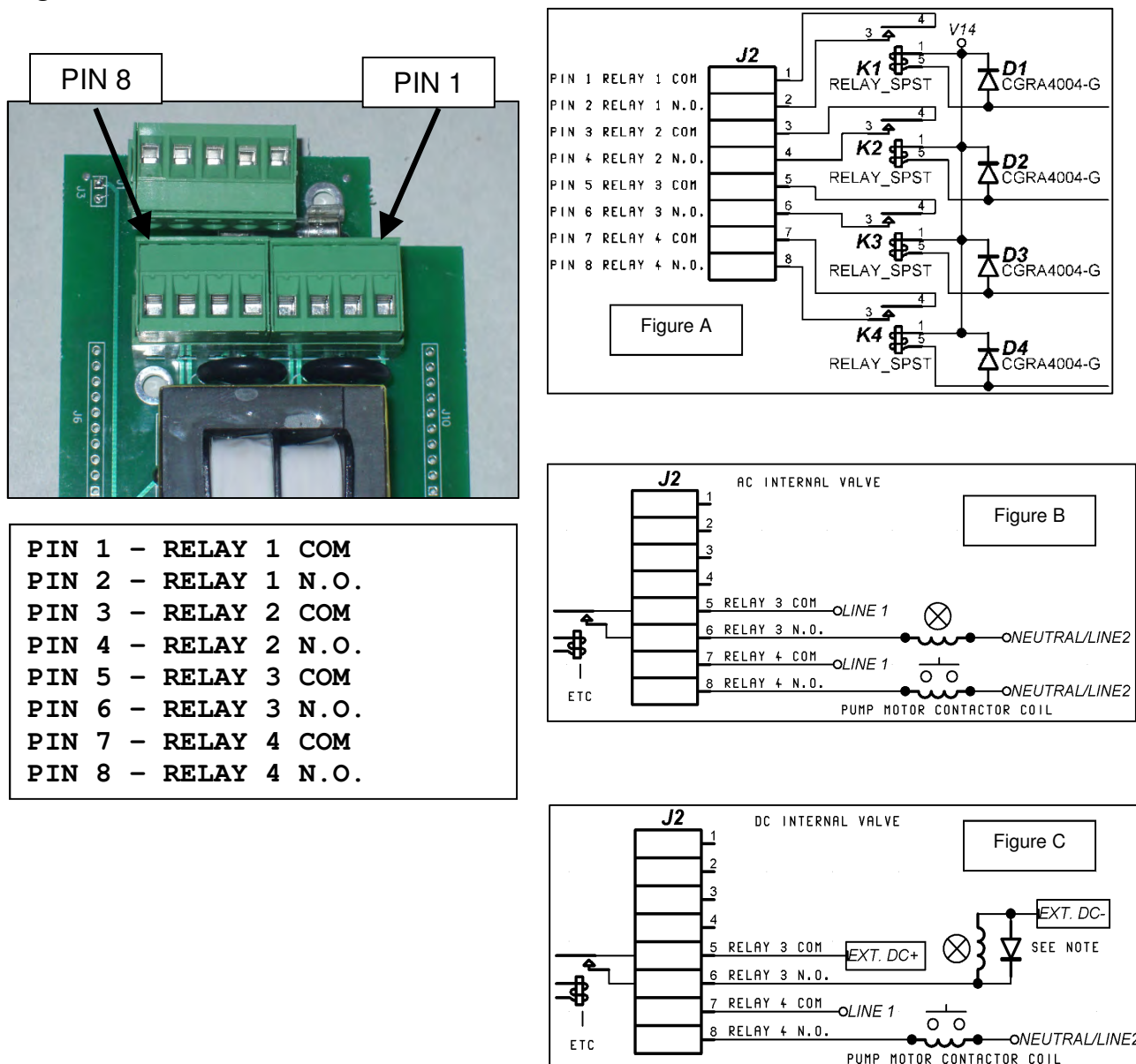

SECTION 8 – REGISTER WIRING

REGISTER WIRING

The photo below shows how the register wires are terminated to the terminal block. Strip about 0.3 inches of insulation and twist the strands of wire tightly before clamping. Check to see that there are no stray strands after terminating and double-check colors and pin numbers before closing up. These are Intrinsically Safe circuits and no modification or other connections are allowed.

Figure 6. REGISTER CONNECTOR WIRING DETAILS

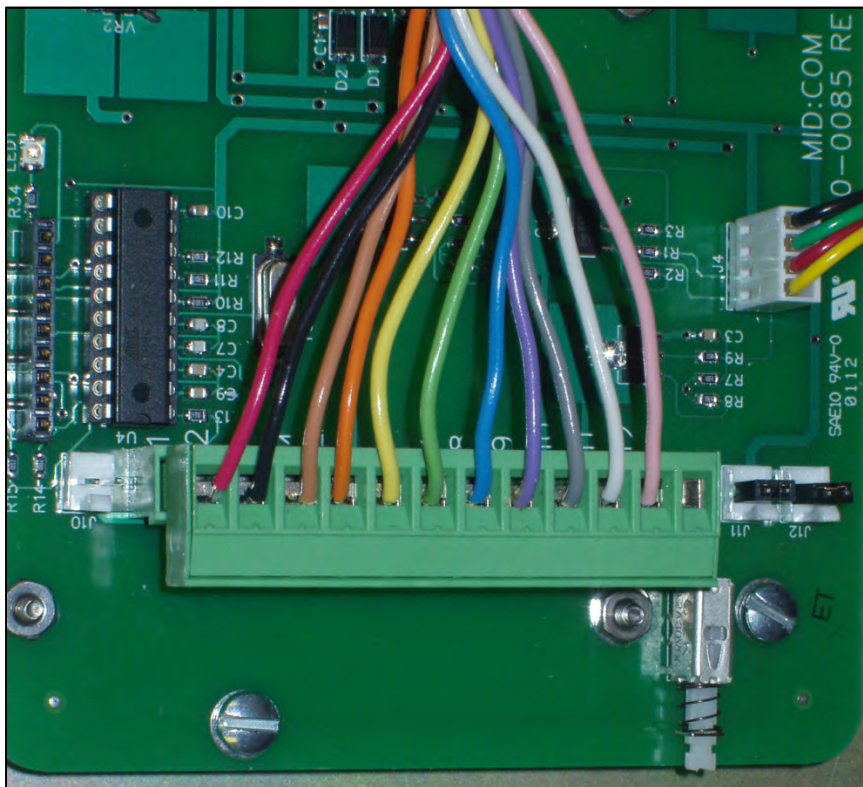

PIN 1	-	RED
PIN 2	-	BLACK
PIN 3	-	BROWN
PIN 4	-	ORANGE
PIN 5	-	YELLOW
PIN 6	-	GREEN
PIN 7	-	BLUE
PIN 8	-	VIOLET
PIN 9	-	GREY
PIN 10	-	WHITE
PIN 11	-	PINK
PIN 12	-	NOT USED

NOTE: THESE CIRCUITS ARE INTRINSICALLY SAFE, NO ADDITIONS OR MODIFICATIONS ARE ALLOWED.

SECTION 9 – CONTROL BOARD CONNECTIONS

CONTROL BOARD CONNECTIONS

The photo below shows the Control Board connections for printer, remote pulser, serial communications, and FMS. Each is detailed in the following section. Note that all the connections exit through the side conduit hub only and are NOT intrinsically safe circuits.

NOTE: J2, J3, AND J4 REQUIRE FACTORY TERMINATED CABLES.

Figure 7. CONTROL BOARD CONNECTION DETAILS

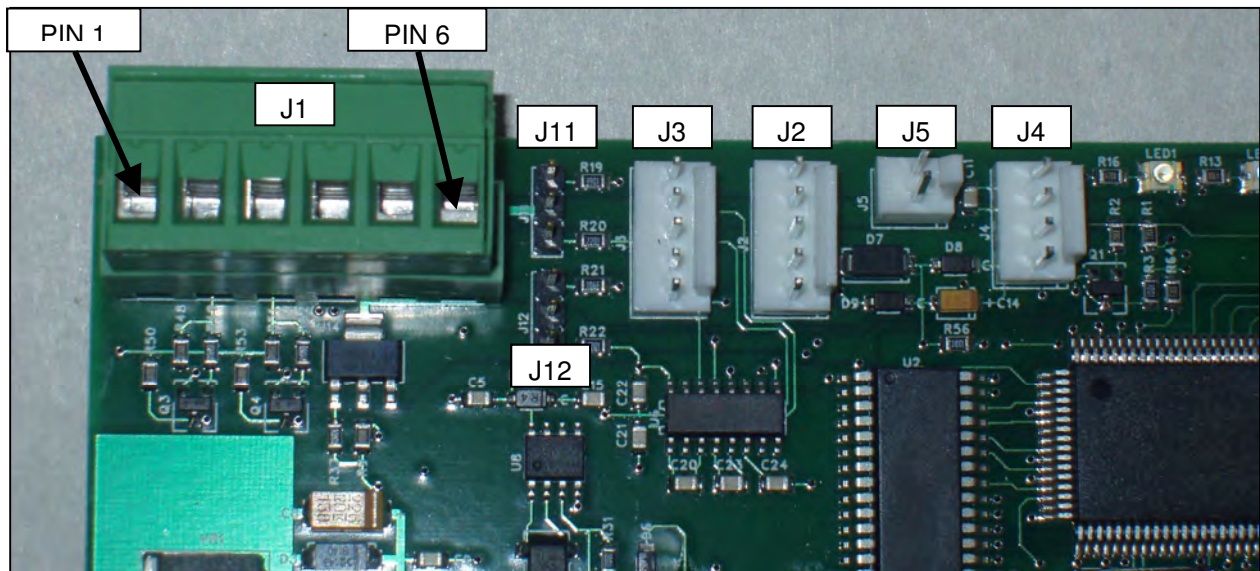

J1 PIN 1 - +12 VDC
J1 PIN 2 - AUTHORIZATION INPUT
J1 PIN 3 - AUXILIARY INPUT 2
J1 PIN 4 - PULSE OUTPUT
J1 PIN 5 - OUTPUT 2
J1 PIN 6 - SIGNAL GROUND

J11 - PULSE OUTPUT PULLUP JUMPER
J12 - OUTPUT 2 PULLUP JUMPER
J2 - SERIAL COMMUNICATIONS/PROGRAM LOADING
J3 - SERIAL PRINTER
J4 - REMOTE PULSE TRANSMITTER
J5 - FACTORY TEST POWER

SECTION 10 – FUEL MANAGEMENT SYSTEM

FUEL MANAGEMENT SYSTEM (FMS) WIRING

Fuel Management Systems (also known as CardLocks, KeyLocks, etc.) have been available for a long time from a number of manufacturers. There are many different models that share some commonality but they can have distinct differences. It is beyond the scope of this document to describe how to connect to any specific device but instead this document will describe how the inputs and outputs of the LTIS work and show some examples of the hookup to different generic types of FMS inputs and outputs. In the simplest form the connections between the FMS and LTIS allow for the FMS to authorize the LTIS to start a delivery (and also end it if necessary) as well as allow the LTIS to send volume pulses to the FMS so that it can record the delivery.

PULSE OUTPUT FROM LTIS

The LTIS outputs one pulse for each increment of the right-hand digit of the display regardless of decimal position. For example, if there are 2 decimals on the display each pulse represents 0.01 units of volume (gallons or liters). If there is only one decimal then each pulse represents 0.1 units of volume. Typically dispensers use 2 decimals.

As depicted in the figure below each pulse is in a "high" state for 5 ms. The pulse output is in a "low" state for a period of time determined by the flow rate but will not be less than 5 ms at maximum flow rate. The pulse output is configured as an "open collector" or "open drain" transistor with header J11 allowing for pull-up resistors to either +5 VDC or +12 VDC.

Figure 8. PULSE OUTPUT TIMING DIAGRAM

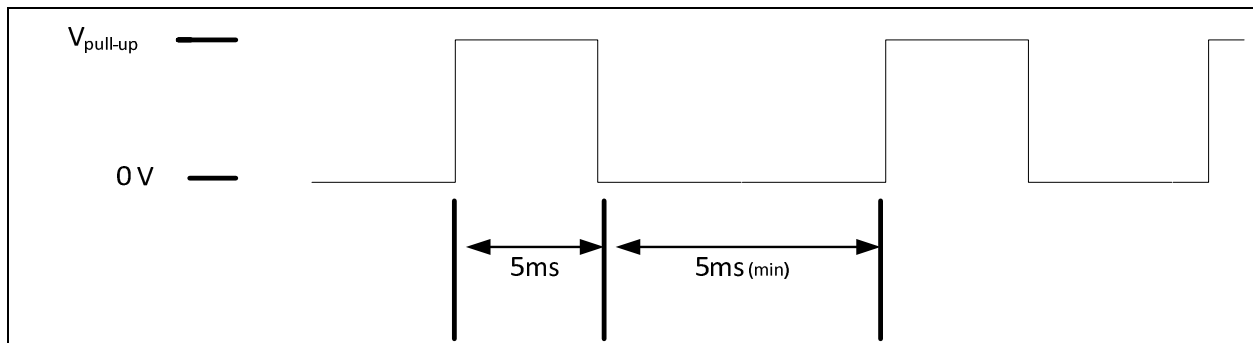

Pin 4 of J1 is the pulse line and Pin 6 (ground) is the return line for the pulse line and all other inputs and outputs. Since all FMS systems are designed to connect to a VEEDER-ROOT electronic pulser the default jumper setting from the factory is to +12 VDC. The "low" state voltage is less than 0.05 VDC under any conditions and typically near 0 VDC. The "high" state voltage depends on the J11 jumper placement and whether or not the FMS has a pull-up resistor on its pulse-input line. It typically does

not matter if the FMS uses a pull-up resistor and J11 is jumpered to either +12 VDC or +5 VDC since when the transistor turns off, the voltage on the pulse line will rise to the FMS supply voltage. In fact J11 does not need to be jumpered at all if there is a pull-up resistor in the FMS.

The return line (LTIS ground, J1 PIN 6) must be connected to the FMS return line. This line in the FMS may or may not be independent of the FMS power supply ground and is typically labeled "common or COM".

The installer needs to determine what is the FMS signal return line and insure that it is connected to the minus side of the FMS DC power supply.

It is important to note that return line connections can be the cause of serious signal degradation and electrical noise due to "Ground Loops". The LTIS logic and power ground is bonded to Earth ground. For solid operation it may be necessary to bond the FMS return line to Earth ground. However in other cases it may be necessary to have the FMS return line left "floating" from Earth ground.

Most FMS systems are compatible with old-style mechanical Reed Switch pulsers as well as electronic pulsers. Reed Switch pulses exhibit "switch bounce" which the FMS has to filter out. The FMS will have a de-bounce feature that may be called "filter" or "high speed/low speed", etc. This is usually selectable with jumpers, dip-switches, or software settings. It is very important that the FMS be set for no filter, high speed, or "electronic" pulser; otherwise some or all of the pulses from the LTIS will be lost or filtered out.

FMS AUTHORIZATION

As shown in the figure to the right, the Authorization input is connected through a resistor to the base of a transistor with a pull-up resistor to +5 VDC. With nothing connected to this input the pull-up resistor keeps the input in a "high" state. The LTIS in SETUP Mode can be configured to be "authorized" for a high or low input. Factory configuration is set for "high" so that no connection to the input

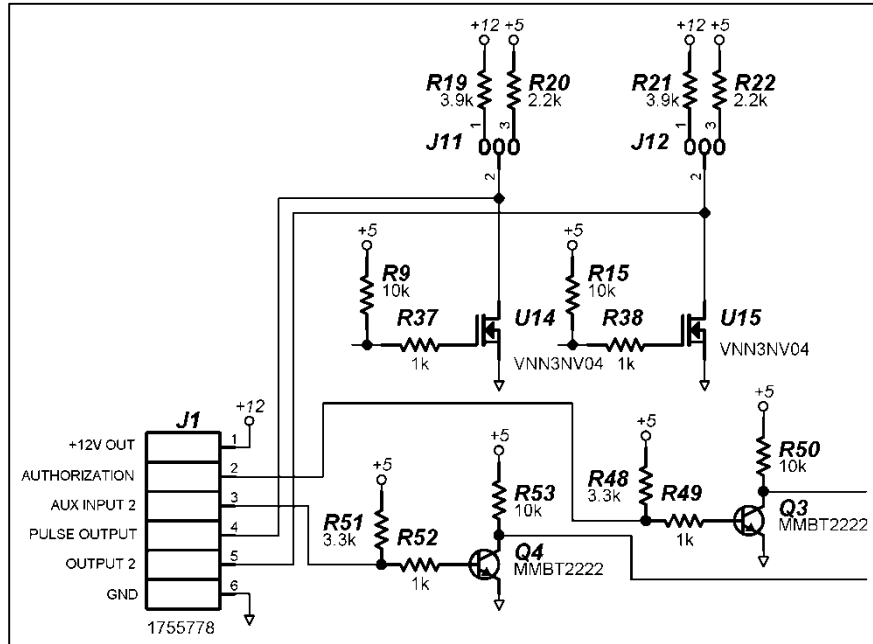

leaves the LTIS ready to be reset and start a delivery. One example of the LTIS being used in the "high" state is when an FMS system is not being used.

A "low" input is a voltage from the FMS that is less than 0.5 VDC; note that the FMS must be able to sink current to pull down the voltage on the LTIS pulse output pull-up resistor. A "high" input is any voltage greater than 0.75 VDC and can be as high as +24 VDC. An open circuit such open switch or relay contact or a transistor in an "off" state will suffice for a high input to the LTIS since the input has a pull-up resistor.

Common wiring configurations for the Authorization Circuit are shown on the following page.

AUTHORIZATION WIRING

In the figure to the right a switch (either a transistor or relay contact) is connected to common or ground with the other side of the switch going to the

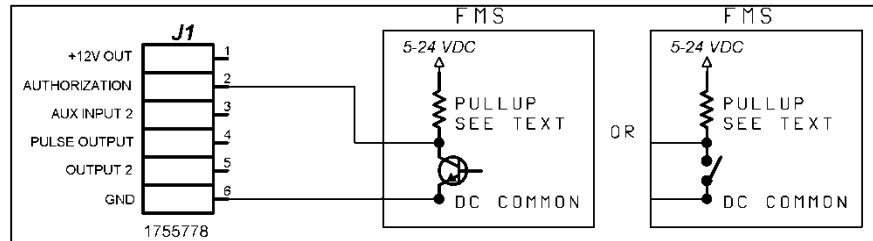

output and possibly a pull-up resistor to the positive supply in the FMS. The pull-up resistor is not necessary but is acceptable if installed. If the switch opens for authorization then the LTIS should be configured for "high" authorization. If the switch closes for authorization the LTIS should be configured for "low" authorization. Note that the common side of the switch may have to be manually wired to the FMS common or logic ground.

In the figure to the right a switch (either a transistor or relay contact) is connect to the FMS power supply rail with the other side of the switch going to the output.

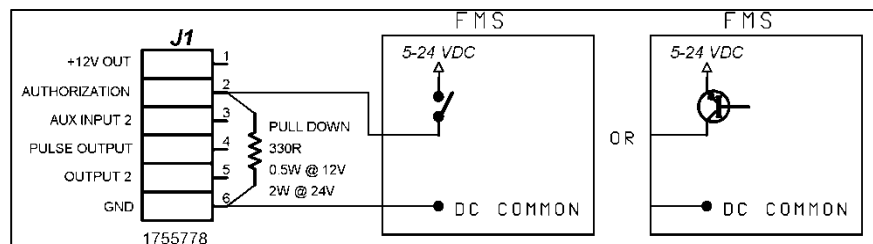

With this configuration it will be necessary to connect 300 OHM (270-330) pull-down resistor with a wattage ratings and connection as shown. If the switch closes for authorization then configure the LTIS for "high" authorization. If the switch opens for authorization then configure the LTIS for "low" authorization. Note that in some instances the switch may have to be manually wired to the FMS power supply rail.

The figure to the right shows an FMS with a 120VAC authorization output. These were common with old mechanical gas pump heads that used motors

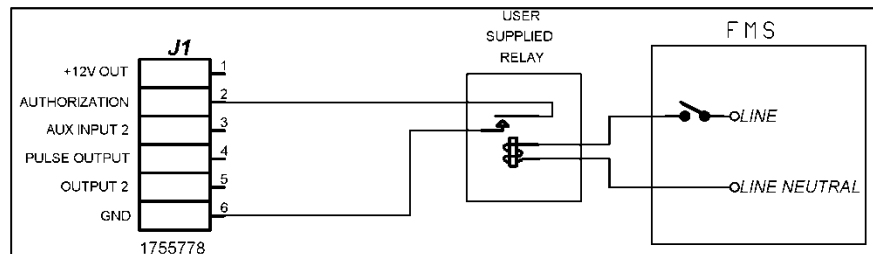

to reset the register but many current FMS still system have this output or can be wired to have one. If this is to be used with an LTIS then a separate installer supplied relay needs to be wired as shown. The LTIS should be configured for "low" authorization.

Figure 9. FUEL MANAGEMENT SYSTEM CONNECTOR (J1)

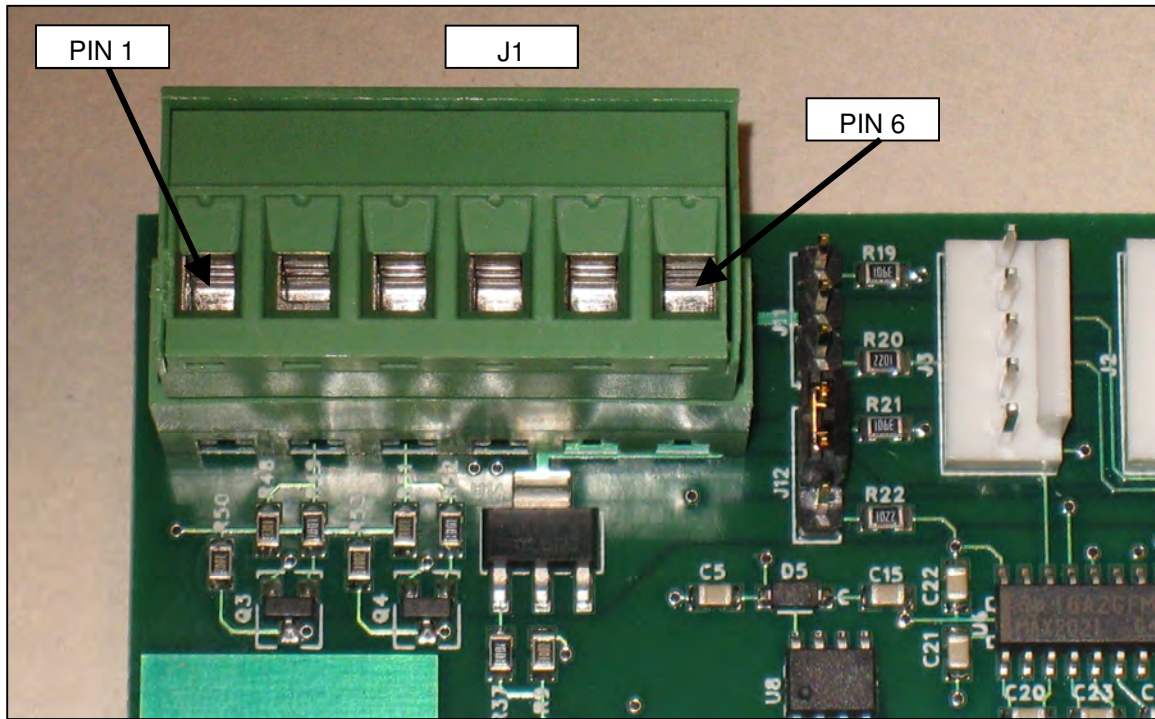
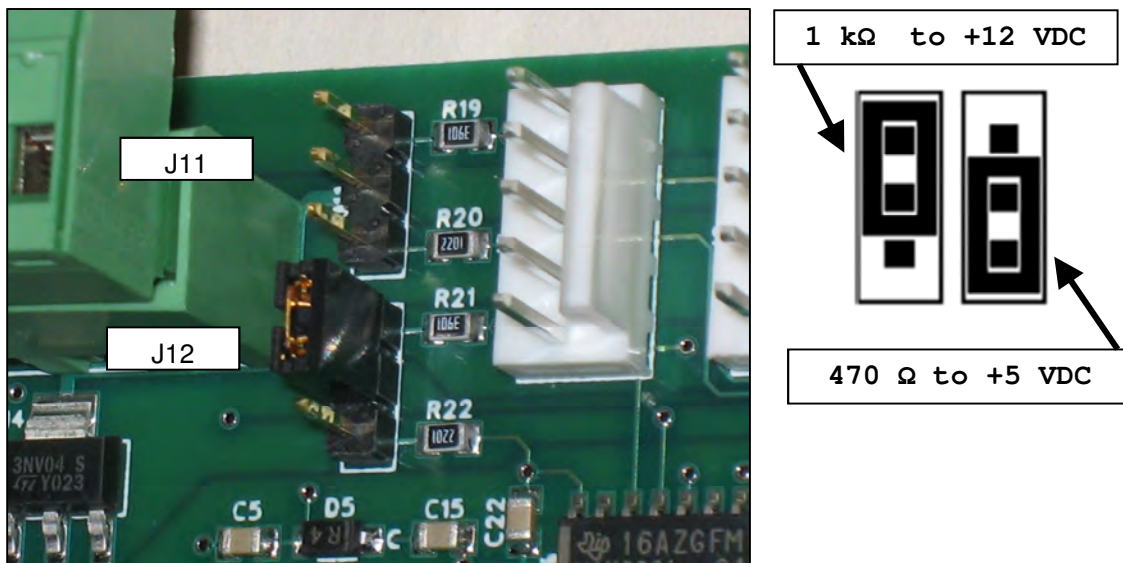

Figure 10. OUTPUT 2 PULLUP JUMPER (J12) SET FOR +12 VDC



SECTION 11 – REMOTE PULSER WIRING

REMOTE PULSER WIRING – MID:COM MODEL PT-10

As shown in the figures below, the PT-10 pulser is wired to the LTIS using a pre-terminated factory supplied cable (MID:COM part number 702-0121). The PT-10 cable is connected to the Remote Pulser Transmitter connector (J4) in the LTIS. The PT-10 cable should be cut to length and terminated to the PT-10 terminal block with the following wire colors, descriptions and terminal positions.

Figure 11. REMOTE PULSER CABLE CONNECTOR (J4)

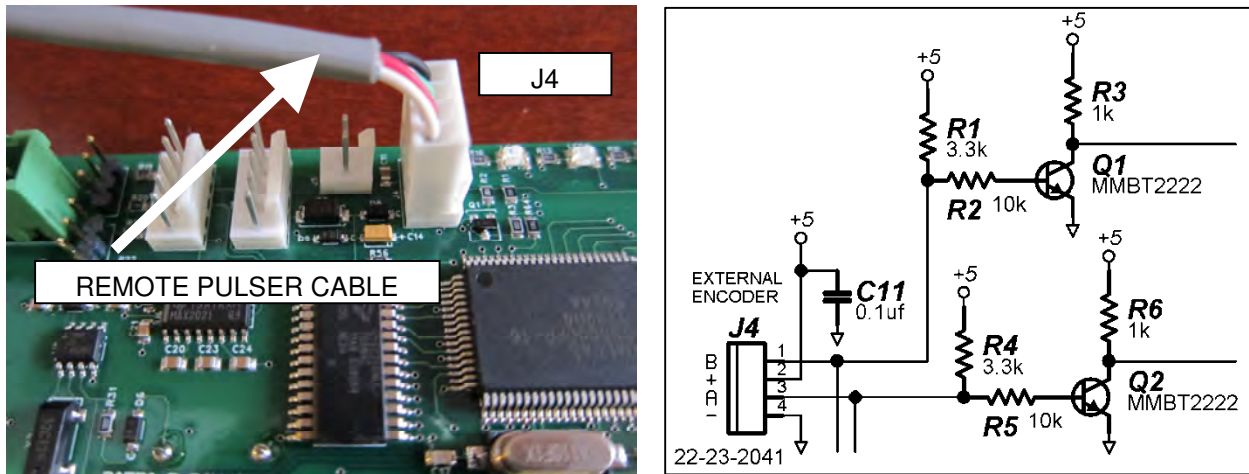
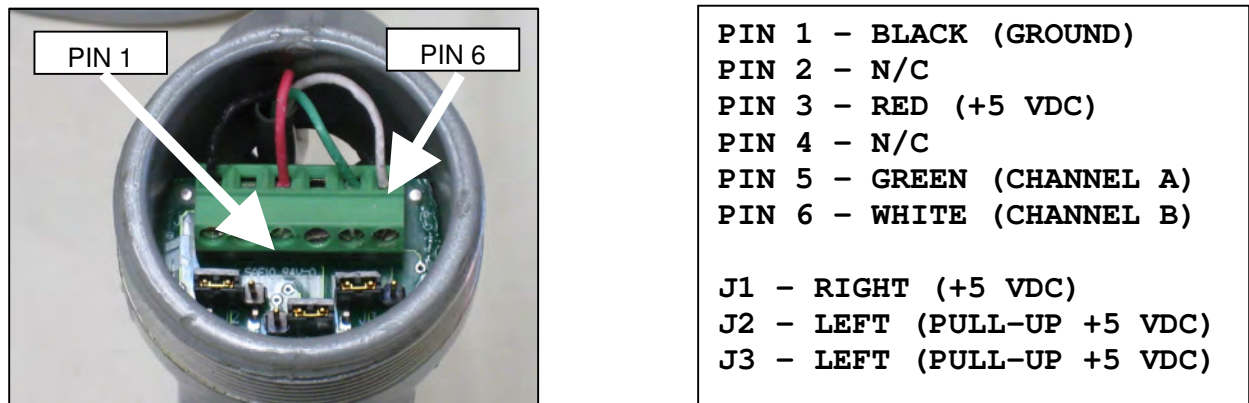

Figure 12. PT-10 REMOTE PULSER LTIS CABLE CONNECTION



The two jumpers closest to the terminal block (J2,J3) need the left two pins jumpered for pull-up resistors to +5 VDC. The other jumper (J1) needs the right two pins jumpered for +5 VDC operation.

Note that the PT-10 must be wired using rigid conduit. Before installing the conduit make sure the electronics housing is completely down on top of the meter adapter. Turn the housing back and forth slightly while seating the seal screws against the flat

facets on the meter adapter. Tighten the screws no more than 1/4 turn after finger tight. Next install the conduit. It is very important that the conduit does not put any strain on the housing so use a flex connector or stub the conduit into another box or conduit body such that adjustments can be made to the conduits to relieve any strain on the housing.

Figure 13. PT-10 REMOTE PULSER CONNECTOR AND JUMPERS

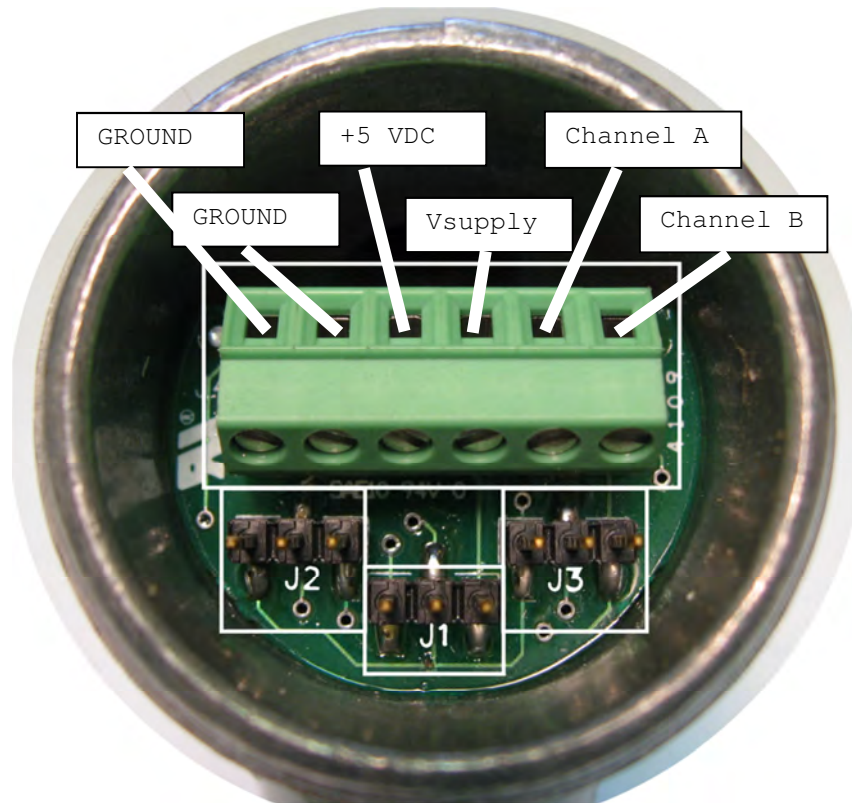

Channel A pullup to **Vsupply**



Channel B pullup to **Vsupply**



Channel A pullup to **+5 VDC**



Channel B pullup to **+5 VDC**

J2

J3



Input Voltage = **+5VDC**



Input Voltage = **Vsupply**

J1

MID:COM MODEL PT-10 – ELECTRICAL WIRING

SUITABLE FOR USE IN CLASS I, DIVISION 1, GROUPS C AND D HAZARDOUS LOCATIONS OR NONHAZARDOUS LOCATIONS.

WARNING – EXPLOSION HAZARD – DO NOT DISCONNECT EQUIPMENT WHILE THE CIRCUIT IS LIVE OR UNLESS THE AREA IS KNOWN TO BE FREE OF IGNITABLE CONCENTRATIONS.

WARNING – EXPLOSION HAZARD – SUBSTITUTION OF ANY COMPONENT MAY IMPAIR SUITABILITY FOR CLASS I, DIVISION 1.

All wiring must be in accordance with the National Electrical Code NFPA 70. In particular, if the unit is to be used in a Class I, Division 1 hazardous location the installation and wiring must be in accordance with Article 500 of this publication.

SECTION 12 – PRINTER WIRING

PRINTER WIRING

The LTIS can interface with a variety of impact and thermal printers, both roll type and slip (ticket) type. As shown in the photos on the following pages, the factory supplied 3 wire cable plugs onto connector J3. The cable exits the enclosure through the communication conduit hub and is then routed to the printer. This sounds simple but in reality it is not and we recommend that you contact us to determine the best solution for installation and wiring.

There are a number of things to consider. The most important consideration is where the printer is to be located. No printers are Listed for use in a Division 1 Hazardous location. A Division 1 Area is all the space within the dispenser enclosure and also within a 5 foot sphere surrounding the fill point (hose end). The less hazardous Division 2 Area extends 15 feet from the dispenser in all directions and up to 48" above grade. Division 2 also exists between the 5 foot Division 1 fill point sphere and a 15 foot sphere. Since printers in general are basically "non-incendive" a local Authority Having Jurisdiction (AHJ) could approve the use of a non-listed printer in a Division 2 area. Check first. Complicating the hazardous location issue is how the printer will be powered. Most printers require +24 VDC which the **LTIS DOES NOT SUPPLY**. Therefore power needs to be brought to the printer and also must comply with Division 2 requirements. In general it is best to mount the printer in a building, office, or kiosk where a hazardous area does not exist. For more information on Divisions see NFPA 58 Section 6.22.2.

The printer cable must be run in rigid conduit until it exits the Division 1 area. From there it may be run in any type of listed conduit. The factory can supply any length of cable, up to 100 feet, with the LTIS end pre-terminated and with the printer end terminated (or not). The LTIS connector can be pulled through 1/2" conduit. Cable runs longer than 100 feet are not recommended but if they test out on site they are acceptable. Another option is to use the MID:COM wireless printer interface which eliminates burying cable and offers a range of up to 250 feet if the radios are in line of sight.

Figure 14. PRINTER WIRING DETAILS (J3)

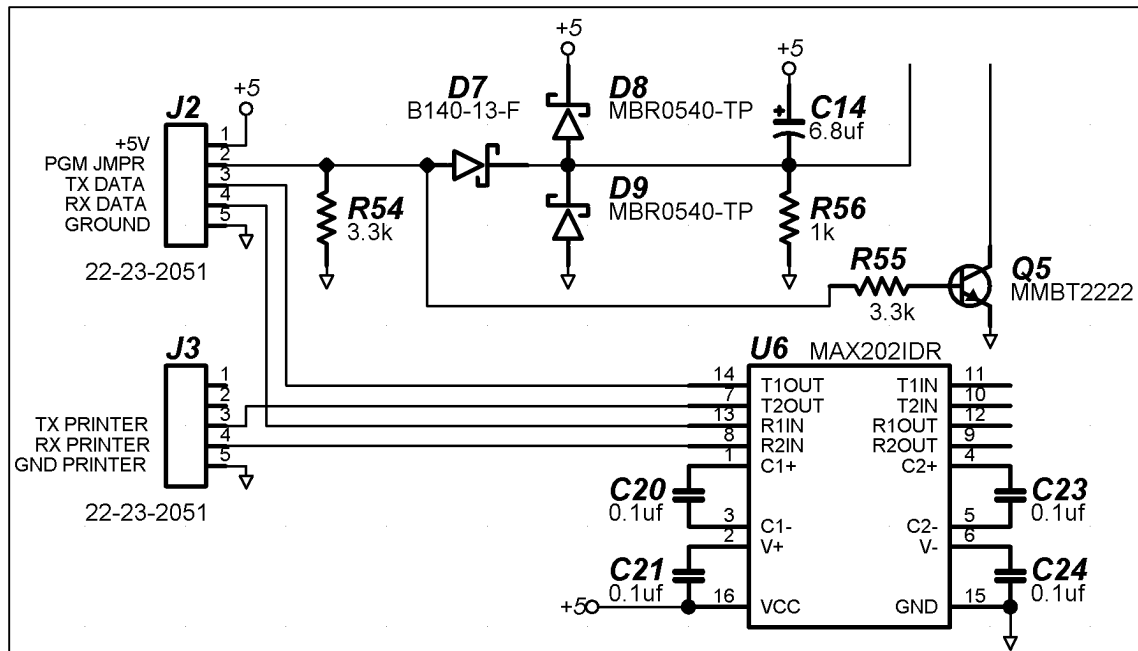
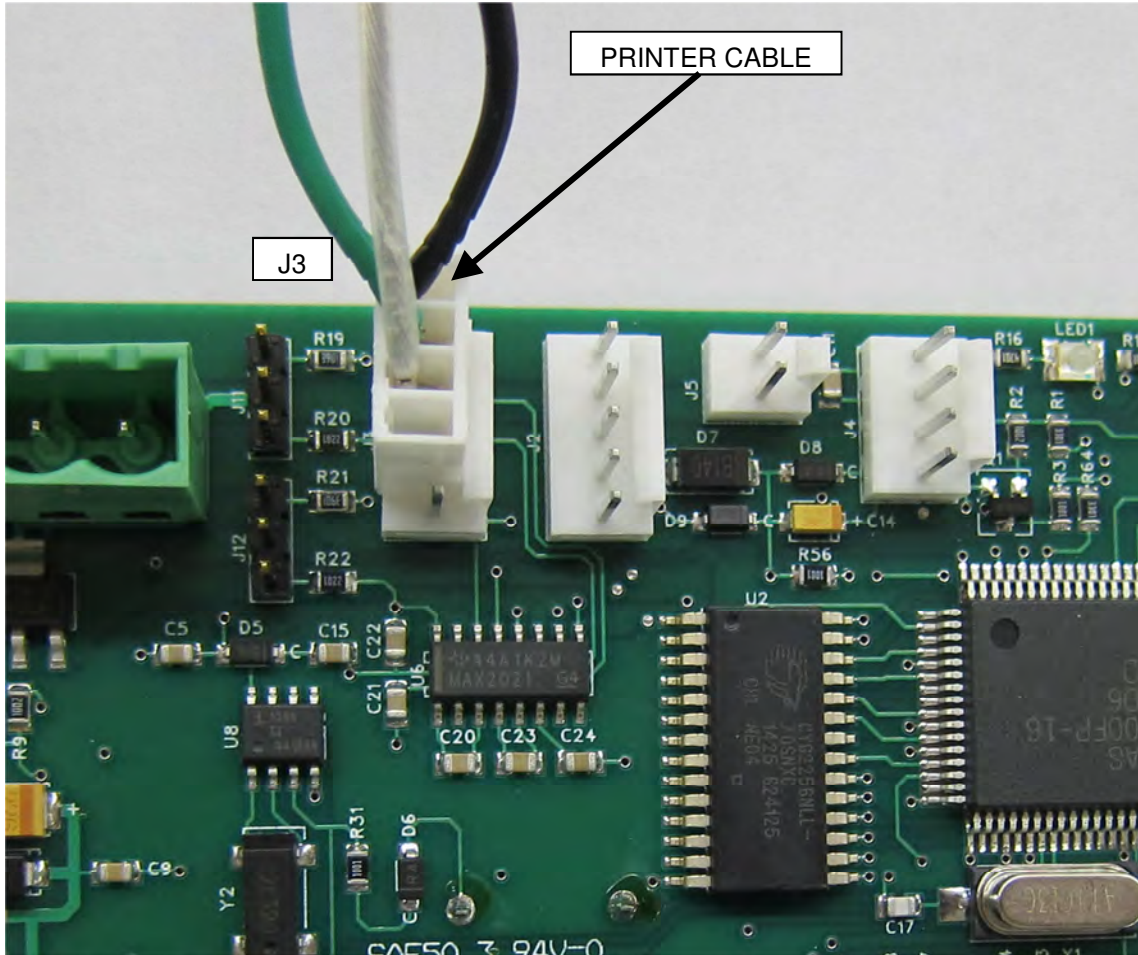

SECTION 13 - TROUBLESHOOTING

TROUBLESHOOTING OVERVIEW

The most common problems requiring field troubleshooting have to do with hooking up external devices such as remote pulsers (MID:COM PT-10) and/or a Fuel Management System (FMS). The following tests require a Digital Voltmeter (DVM), preferably auto-ranging. The voltmeter should be set for **DC Volts**.

TROUBLESHOOTING PT-10 REMOTE PULSE TRANSMITTER

Two possible problems with a PT-10 installation are:

- 1) The LTIS counts when there is no flow, or
- 2) The LTIS does not count when there is flow.

If the LTIS counts when there is no flow the problem is usually that the two parts of the pulser are not mated properly. There is a magnetic coupling between the two parts and it is very important that the top surface of the meter adapter and the inside surface of the pulser are flush with each other and the seal screws are seated on the flat facets of the meter adapter. If there is a gap the pulser may put out spurious pulses.

If the LTIS does not count while there is flow first double-check the wiring and jumper settings described under Remote Pulser Wiring. Make sure the wire color positions correspond to the photos to check that the cable was terminated correctly at the factory.

VOLTAGE CHECKS

1. At the PT-10 check the voltage between the black wire (Pin 1, Ground) the red wire (Pin 3, Power). **The voltage should be +4.95 VDC to +5.05 VDC. If the voltage is not present or is less than +4.9 VDC re-check the wiring.**
2. With the pump running and product flowing through the meter, check from ground to the Green and then the White wires. The voltage should be approximately +2.3 VDC indicating the meter is seeing a square wave pulse output. The voltage is not critical but if it is near 0V or +5 VDC there is a problem. Remove the wire from the terminal block and again check the voltage on the terminal block screw. **If the voltage is still near 0V or +5 VDC the PT-10 is faulty. Otherwise the problem in the LTIS Power Control Module (PCM).**
3. If flow cannot be established there are two ways to simulate pulses. First loosen the seal screws and the conduit connection on the PT-10 so that it can be turned slightly. With the meter probes on the black and green or white wires slowly rotate the pulser back and forth. If the pulser is operating correctly the voltage on each wire will alternately switch from less than 50 mV to +4.3 VDC. The two channels can be both high or both low or opposite of each other at any pulser position. The same test can be accomplished if there is a spare meter adapter available. Install the meter adapter in the pulser and turn the input shaft slowly clockwise looking at the end of the shaft.
4. The wiring shown and described is valid for a PT-10 installed on a Red Seal 1" meter. The LTIS detects the direction of the rotation of the pulser. **If another brand of pulser is being used it is important that it is set up for +5 VDC operation and it may be necessary to reverse the connections of the green and white wires for proper flow direction detection.**

TROUBLESHOOTING PULSE OUTPUT TO FMS

- Disconnect the pulse output wire from the FMS.
- With no flow through the meter and the LTIS not counting, check the voltage from ground to the pulse output wire. The voltage should be less than 10mV.
- With flow through the meter and the LTIS counting check the voltage. If the pulse output pullup resistor is jumpered for +12 VDC there should be approximately 300mV to 400mV on the line, depending on the flow rate. If pulled up to +5 VDC the reading will be about 100mv to 150mV. The actual voltage is not as important as the fact that there is activity on the line. ***If there is no activity the LTIS is faulty.***
- Perform the same tests with the wire connected to the FMS.
- ***If the no flow voltage rises above +0.2 VDC, or with flow the activity on the line stops or reads significantly lower than the disconnected reading then there is a problem with (or something miswired in) the FMS.***
- A higher voltage with flow is not a problem.
- Double check that the LTIS ground is connected to the FMS "common" or logic ground.

TROUBLESHOOTING AUTHORIZATION INPUT FROM FMS

1. Disconnect the authorization line from the FMS.
 2. Set the LTIS authorization setting to "HIGH" as follows:
 - a. Press and hold the MODE key until **SETUP** is displayed.
 - i. Press START/STOP.
 - b. Enter the access code using the ARROW keys.
 - i. Press START/STOP. (Note default code is **000000**).
 - c. Press and hold MODE until **AUTHR** is displayed.
 - i. Press START/STOP.
 - d. Use the UP/DOWN arrows keys to display **HIGH**.
 - i. Press START/STOP.
 - e. Press and hold MODE until **EXIT** is displayed.
 - i. Press START/STOP.
- If LTIS is set for HIGH authorization (factory default) a connection to the authorization line is unnecessary.
 - Press START/STOP. The LTIS should go through it's reset cycle and start the pump. Press START/STOP to end the delivery.
 - Next connect the authorization line to ground.
 - Press START/STOP. ***If the LTIS fails to reset then the LTIS authorization line is wired correctly to the LTIS and it is functioning properly.***
 - If necessary for the FMS, reset the authorization to "**LOW**".
 - Refer back to FMS WIRING and the FMS manual to determine the problem.

INDEX

120 VAC.....	14, 15, 17	Power Control Module.....	10, 32
240 VAC.....	14	printer.....	19, 28
AHJ.....	28	printers.....	28
Authority Having Jurisdiction.....	28	Printers.....	13
authorization.....	23, 33	PT-10.....	25, 31, 32
authorize.....	20	pulse.....	20, 22, 32, 33
authorized.....	16, 22	Red Seal.....	32
CardLocks.....	20	Reed Switch pulsers.....	21
Class 1 Division 1.....	9	Register.....	10, 13
CLASS 1 DIVISION 1 OR 2	9	relay.....	10, 16, 22, 23
communication wiring.....	10	Relay 1.....	16
compression fittings.....	10	Relay 2.....	16
Control Board.....	13, 19	Relay 3.....	16
Control Drawing.....	10	Relay 4.....	16
cross-talk.....	10	relay wiring.....	10
de-bounce.....	21	relays.....	13, 16, 17
Digital Voltmeter.....	31	remote pulser.....	19
diode.....	17	Remote Pulser Transmitter.....	25
dispenser.....	13, 16, 28	remote pulsers.....	31
Division 1 Area.....	28	Remote Pulsers.....	13
Division 2 Area.....	28	RTD Probe.....	10
electronic pulsers.....	21	seal-off.....	10
EXPLOSION HAZARD	9, 27	seal-offs.....	10
FMS.....	13, 16, 19, 20, 21, 22, 23, 31, 33	serial communications.....	19
Fuel Management Systems.....	13, 20	signal degradation.....	21
Group C and D.....	9	signal return line.....	21
Hazardous Locations.....	9, 10	solenoid.....	17
interference.....	10	Stage 2.....	16
Intrinsically Safe.....	10, 18	switch bounce.....	21
IS10, 27		Temperature Compensator RTD Probe.....	10
IS circuits.....	10	Temperature PCB.....	10
KeyLocks.....	20	terminal block.....	16, 18, 25, 32
low voltage peripherals.....	10	troubleshooting.....	31
LP gas dispenser.....	13	VEEDER-ROOT electronic pulser.....	20
LTIS counts when there is no flow ..	31	voltage is not present	32
no-flow timer.....	16	voltmeter.....	31
open collector.....	20	wireless printer.....	28
open drain".....	20	zero reset.....	16
PCM.....	10, 32		

